



## High Flow in a Compact Body

Jandy MaxHP pumps offer high flow in a compact body. They are ideal for situations that demand maximum flow such as, waterfalls, laminar jets and other water features. Our proprietary impeller and body designs deliver ultra-quick primes and optimum performance. The MaxHP is designed with a compact body so it will easily fit in small equipment areas. It is the perfect choice for a pool with suction cleaner.

### HIGH FLOW RATE



The high flow MaxHP pumps are perfect for medium head water features such as laminar jets, waterfalls, sheer descents and vanishing edge pools. The MaxHP is also a perfect choice for a pool with suction cleaner.

### QUIET TECHNOLOGY



MaxHP pumps incorporate "Quiet Technology" into every pump. This proprietary design controls the flow dynamics within the pump, resulting in less noise and quiet operation.

### GREAT FEATURES



The MaxHP offers many great features including 2 by 2½" quick-connect unions, a flared base for easy anchoring, an ergonomic cam-lock lid with easy to read aligning indicators, and a AO Smith motor.

### SAME COMPONENTS AS PlusHP



For ease of service and maintenance, most components of the MaxHP pumps are interchangeable with the PlusHP line of pumps. The compact body is great for small equipment areas.



# Jandy MaxHP Pumps - High Flow

Jandy's line of MaxHP pumps offer a maximum flow rate in a compact body that is perfect for medium head water features. The MaxHP offers many of the same great features as our flagship pump, the Stealth. For ease of service and maintenance, most of the parts on the MaxHP are interchangeable with the PlusHP line of pumps.



## MaxHP PUMP DIMENSIONS

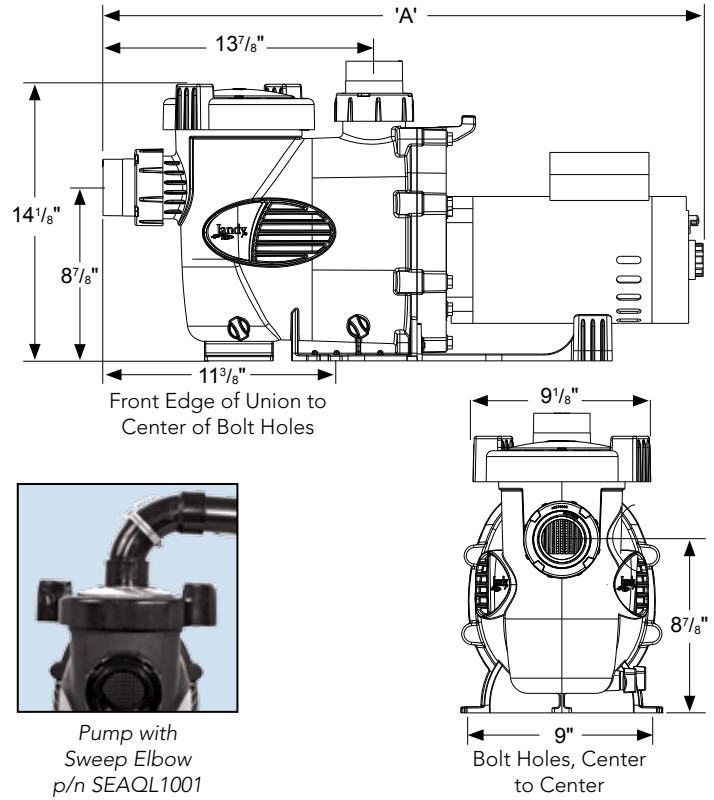

## PERFORMANCE

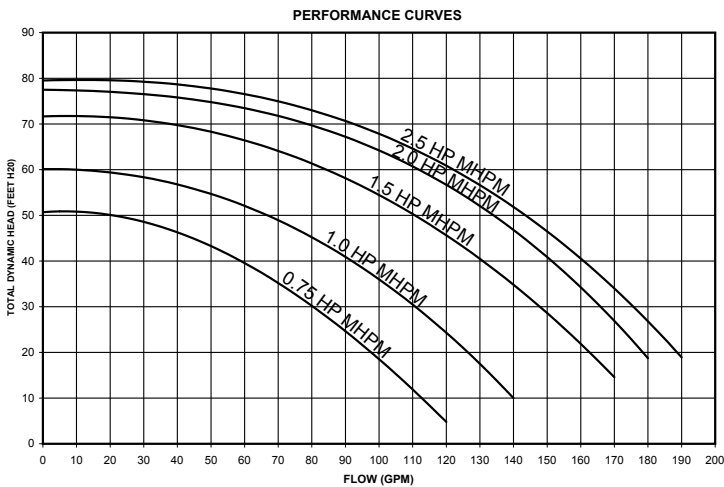

## Specifications for Jandy MHPM Pumps

Model No.	HP	Voltage	Amps	Pipe Size	Carton Weight	Overall Length 'A'
MHPM.75	.75	230/115	5.4/10.8	1½-2"	40.6	29¼"
MHPM1.0	1.0	230/115	7.1/14.2	2-2½"	41.2	28⅞"
MHPM1.5	1.5	230/115	8.0/16	2-2½"	42.6	29¼"
MHPM2.0	2.0	230/115	11.2/22.4	2-2½"	54.6	31⅞"
MHPM2.5	2.5	230	11.5	2-2½"	48.6	30"



**ALL JANDY PRODUCTS WORK SEAMLESSLY TOGETHER**

Jandy Control Systems manage our complete line of technologically advanced products.



Pumps • Filters • Heaters • Air Energy Heat Pumps  
 Controls • Lights • Water Purification Systems • Valves  
 Water Features • Cleaners • Accessories



L0985A